



Model EBDL-B
EBDL Motor for Dampers-by-Others

Application and Design

The Young Regulator EBDL-B is a motorized balancing damper assembly for dampers by others. A convenient bracket and motor kit allow for the simple installation of a brushless DC Belimo actuator onto an existing damper. This motor requires no power from the building. All power to operate the damper is provided by our hand held power pack positioner, the EBDLP.

Simply slip the plate over the damper shaft and fasten it to the damper frame. Secure the base of the motor to the motor plate with the provided hardware, and tighten the rotation clamp onto the damper shaft. The motor is provided with a 3 wire pigtail attached to the motor terminals. The other end of the pigtail has a coupler to receive our EBDC Cable, a 6 wire plenum rated shielded cable, which is available in varying lengths. The cable is run from the damper motor to the location from where the damper will be controlled. Cables are most commonly terminated within a wall jack located in the office, or out of sight in a nearby closet or mechanical room. A concealed ceiling cup is another available termination.

The EBDLP Power Pack Positioner is plugged into the jack, providing the power required to operate the damper. Arrows on the EBDLP drive the motor open or closed, and the damper position is shown on a meter as a percentage open.

Controlling an inaccessible balancing damper has never been easier.



REQUIRED ACCESSORIES	TERMINATION OPTIONS
EBDLP (Positioner) <i>One per Order Minimum</i>	EBD-WALL (1,2,3,4,6, or 12) <i>One Port per Damper</i>
EBDC (Plenum Rated Cable) <i>One length per Damper</i>	EBD-301 (Concealed Ceiling Cup)
	EBD-VM (Hook & Loop Fastener)

SHAFT SIZE REQUIREMENTS
3/8" square or 1/2" round



**EBDLP Positioner

BELIMO BRUSHLESS DC ACTUATOR	
Volts	24V DC ± 10%
Watts	1.5W
VA	2.0VA
Timing	95 Seconds
Torque	45 in. lbs.

Minimum and Maximum Air Stops

Quantity	Option	Notes
PROJECT		LOCATION
CONTRACTOR		DESIGN SPECIFIER



Model EBDL-B EBDL Motor for Dampers-by-Others

Sequence of Operation:

The positioner is turned on by plugging in the short cable from the battery pack to the controller. 3 Non-rechargeable 9V lithium batteries power the positioner.

Once the unit is connected to a receptacle, press the down arrow to read the blade position over a range of 0-100% open via a voltage signal that is proportional to the blade angle.

The position of the damper is adjusted by using the up and down arrows on the controller, opening the damper by pressing the up arrow and closing the damper by pressing the down arrow. The meter indicates the exact position of the damper blade.

When finished adjusting dampers at the worksite, be sure to turn the EBDLP positioner off by unplugging the power wire to extend battery life. Positioner should be returned to owner.

Assembly Diagram:

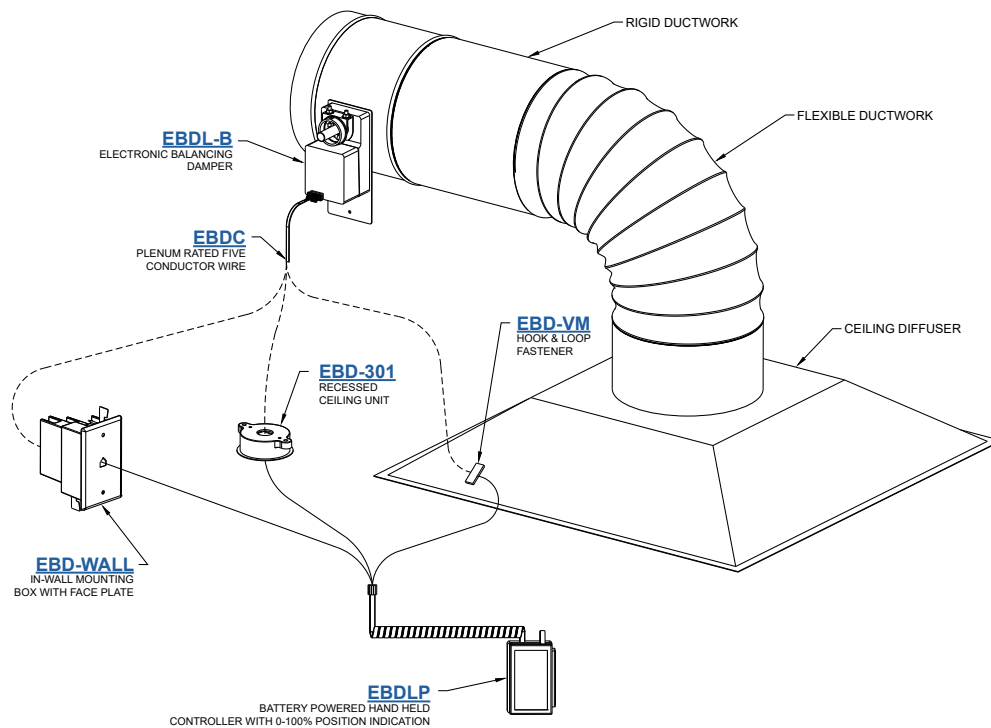

Notes:

1. Coordinate exact location of EBDL and Wall units with architect prior to installation.
2. (3) 9V lithium batteries power the handheld controller. Replace the batteries in the controller with the same type and quantity of batteries. Replacement batteries are available from Young Regulator Co. and many retail outlets. Dispose of used batteries in accordance with local regulatory and environmental codes.
3. The handheld position controller shall be turned on via the short cord from the battery pack to the positioner.
4. Once powered on, plug the coil cord into the wall unit and the controller screen will show it is connected to an MPL actuator.
5. The position of the damper blade is set by using the up and down arrows of the handheld controller. To change the blade position, press the down arrow once and then the OK button. The up and down arrows will now control the blade position of the damper.
6. If at any time the handheld controller's screen is unrecognizable, unplug the short cable from the controller and plug it back in to restart the device. Follow steps 4 and 5 to adjust any other dampers.
7. EBDC cables shall not be longer than 1,000 ft. in length. Field installed terminations may be required for a complete assembly. Field connection between 24V DC motor and termination shall be made with snap on connectors installed by the factory.
8. One EBDLP handheld position controller shall be required per job.

Wall Port Options:

