



Young Regulator Co.

7100 Krick Rd • Walton Hills, OH 44146

P: 440-232-9700 • F: 440-232-8266

www.youngregulator.com

Model 4092

Electronic Bypass Damper Round
Pressure Reducing Damper

Application and Design

The Young Regulator 4092 round bypass damper regulates the total airflow in the system by diverting the excess airflow through a ducted return or ceiling plenum.

An increase in static pressure is sensed by the built in static pressure sensor/controller through the probe. At the desired static pressure, (adjustable by the installer) the motor will begin to modulate the damper open to bypass the excess air flow, reducing static pressure. The damper will open until the desired static pressure is attained. Damper blade will stall and pressure will be maintained until another change in pressure. If zones are satisfied and more zone dampers close, bypass damper will open further. If zones require more air and zone dampers open, pressure reducing damper sensor will sense a decrease in pressure and the bypass damper will close.

The system can also be used to reduce downstream static by limiting the amount of air going into a branch. In that case the controller signals an "Open" on drop in static and a close on Pressure rise.



Static Pressure Sensor/Controller

Solid-State design with built-in LED to indicate damper operation.

Differential Pressure Setpoint Range	0.08 to 1.2 InWC
Operating Range	-40° to 190° F
Electrical Switch	Solid State Switching 1Amp @ 24VAC
Compliance / Enclosure	ETL Recognized / NEMA13 / IP54

Actuator

Brushless 24VAC Motor Power Open/Power Closed

Volts / Watts / VA	24VAC / 1.5W running(0.2W holding) / 2VA
Timing / Torque	35 Seconds / 45 in-lbs
Sizes	8, 10, 12, 14, 16, 18 and 20 inches

Built-in motor stops for minimum and maximum air

Standard Construction

Bypass assembly of damper, actuator and static pressure sensor are prewired at the factory for a reliable, economical means of controlling pressure in a pressure dependent VAV system.

Shell	20 ga, Spiral Steel Shell
Shaft / Bearings	½" Plated Steel / Oil Impregnated Bronze
Seals	Full Circular Closed Seal Gasket - Less than 1% leakage @ 3InWC
Blade	20 ga. Galvanized Steel, Elliptical for linear control of air ±1% accuracy

Quantity	Diameter	Bypass or Pressure Reduction	Notes
PROJECT			LOCATION
CONTRACTOR			DESIGN SPECIFIER



Young Regulator Co.

7100 Krick Rd • Walton Hills, OH 44146

P: 440-232-9700 • F: 440-232-8266

www.youngregulator.com

Model 4092 Electronic Bypass Damper

GENERAL INSTRUCTIONS FOR BYPASS DAMPER ASSEMBLY

HOW THE BYPASS SYSTEM WORKS

As the individual zone dampers open and close, the system static pressure will rise and fall. In order to maintain proper air flow and static pressure through the HVAC system, a bypass system incorporating a reversible type motorized damper and a static pressure control is used. The static pressure control is equipped with solid state switching

INSTALLING THE BYPASS DAMPER AND STATIC PRESSURE CONTROL ASSEMBLY

The bypass damper should be installed with the bypass air being discharged into the return air plenum or above the ceiling if this area is used as a common return (see drawing). The bypass damper must be installed so that the diaphragm of the static pressure control is in the vertical position. The high-pressure side of the static pressure control (P1, dark gray) should be connected to the sensing probe that is inserted into the main supply plenum downstream of the bypass damper and at least 2 to 3 feet from the air handling unit in a straight section of duct. The sensing tube furnished is 2-1/2" (6.4cm) long that is connected to the pressure control with 1/4" O.D. plastic tubing. The probe should be installed and sealed into the duct with the arrow oriented in the direction of airflow. The sensing probe, plastic tubing and mounting fittings are furnished with the damper assembly.

Before adjusting the pressure control, the installer should confirm the following:

1. that the HVAC system has been properly balanced.
2. that all zone dampers are in the open position.

SPECIFICATIONS FOR BYPASS DAMPERS

- Pressure Set Point Range: 0.08" to 1.20" (2-30.5mm) InWC.
- Sensing Element: Neoprene diaphragm
- Electrical Connections: Two field connections.
- Pressure Connections: Barbed for 1/4" O.D. plastic tubing.
- Case: NEMA13 / IP54 Plastic Enclosure with 1/2" conduit opening.
- Mounting: Damper to be installed with controller diaphragm in a vertical position.

Note:

Bypass damper must be installed so that the diaphragm of the static pressure control is always in the vertical position.

This Drawing of a bypass system is intended to serve only as a guide. Your actual duct work layout may differ substantially.

BYPASS DAMPER AND STATIC PRESSURE CONTROL ASSEMBLY

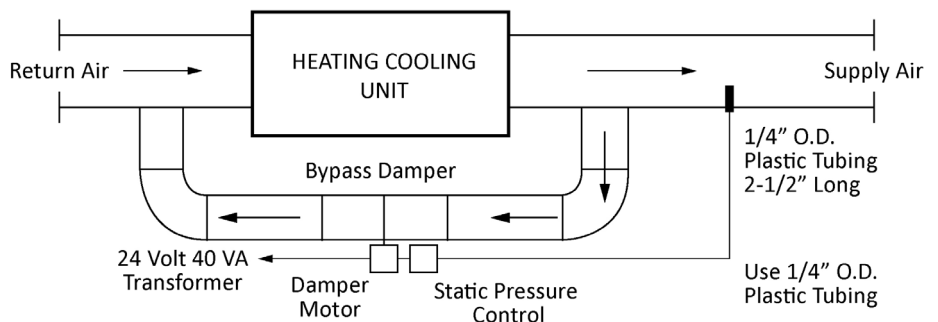

Manufacturers
of

MOTORIZED ZONE DAMPERS
REMOTE DAMPER CONTROLS
MODULATING VAV DAMPERS
DAMPER REGULATORS
VOLUME CONTROL DAMPERS
REGULATOR ACCESSORIES
DAMPER MOTORS & DRIVES



YOUNG REGULATOR COMPANY

7100 KRICK ROAD - WALTON HILLS, OHIO 44146
TELEPHONE (440) 232-9700 • FAX (440) 232-8266
www.youngregulator.com

STAT: NONE

MODE: **BYPASS - STATIC PRESSURE**

MOTOR: Modulating

MODEL: 3092-B
4092-B

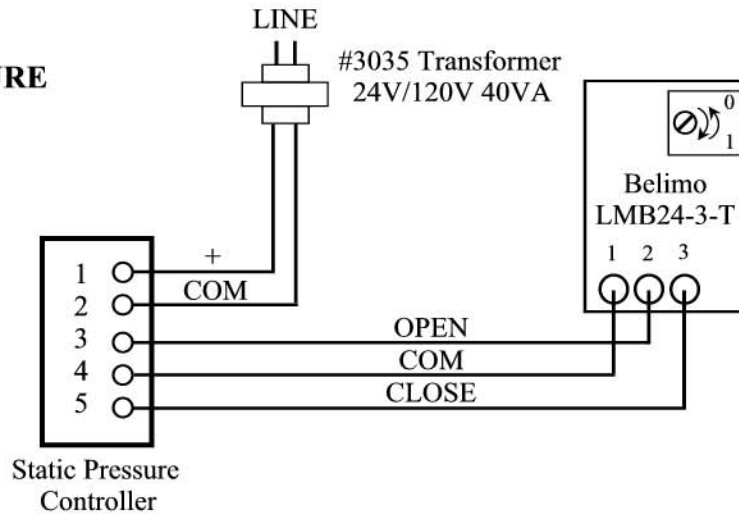

NOTES:

- * 3, 4 and 6 are pre-wired
- * Transformer is separate and wired in the field
- * LED indicator: GREEN - damper opening, high pressure
- * Static pressure relief is factory preset at 0.4" WC
- * Static pressure tubing is connected to P1 port (dark gray)

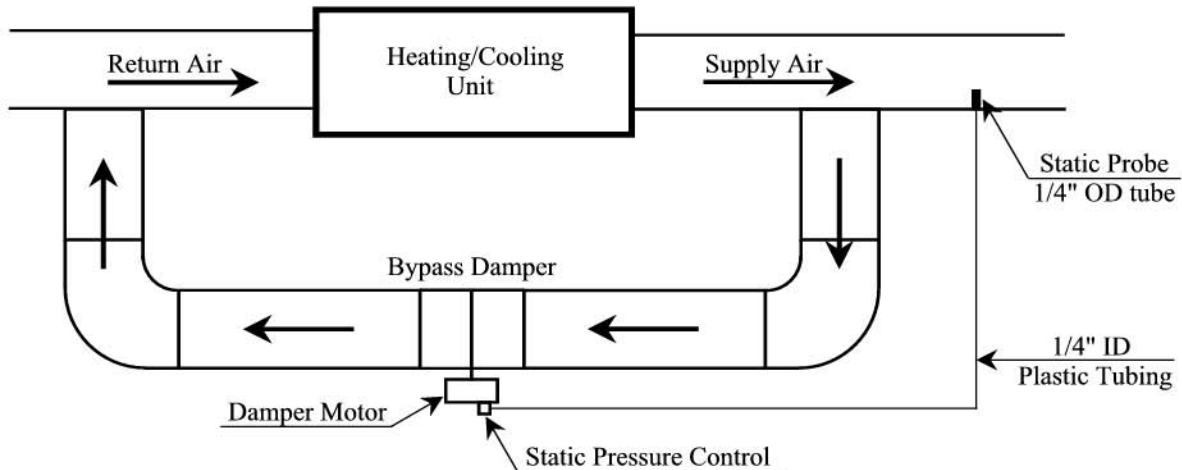

ADJUSTING THE STATIC PRESSURE CONTROL (Models 3092, 4092):

- * Confirm that the HVAC system has been properly balanced
- * Open all zone dampers
- * With the air handler running and the bypass damper system powered
 - turn the static pressure adjusting knob CCW until the bypass damper starts to open (green light ON)
 - turn the adjusting knob CW just enough so that the light goes out and the damper fully closes