

BOWDEN CABLE CONTROLS
DAMPER HARDWARE INCLUDED ON 5020CC DAMPER
THIS HARDWARE IS ALSO INCLUDED IN THE "B" VERSION OF ALL
CONTROL KITS FOR
270-301B - 270-896B - 270-275B, 270-301EZB,
270-302B, 270-700B, 270-275MLB, 270-315B TO ACCOMODATE
"DAMPERS BY OTHERS"

For dampers with 1/2" round or 3/8" square shaft
Optional 5/16" round Rapit or 1/4" square shaft
Optional 1/2" square shaft

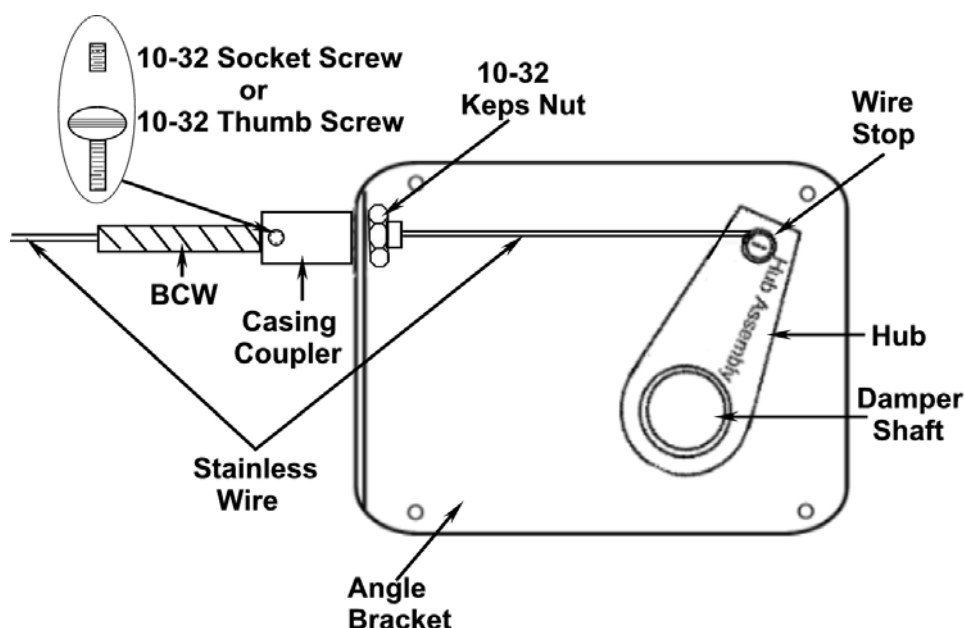

1. Fasten angle bracket to side of damper around shaft.
2. Install hub over shaft with setscrews provided so blade is full closed and lever is at 45 degrees as shown.
3. With stainless steel wire in casing, push casing into casing coupler approximated 1/2" or until it stops, tighten 3/32" allen screw or thumb screw snugly to casing. Fasten casing coupler to center hole in angle bracket with 10-32 keps nut as illustrated.
4. Thread wire through wire casing and into the wire stop on hub with lever at 45 degrees as shown (blade full closed). Tighten the hex head screw on the wire stop to secure wire. When installation is complete, assembly must appear as shown in the above diagram. The angle of the hub must be in the 45-degree position when the damper is full closed.
5. Secure wire casing between damper and controls with wire clip or similar fastener every 4 feet.